

Please check the examination details below before entering your candidate information

Candidate surname

Other names

Centre Number

Candidate Number

--	--	--	--	--

--	--	--	--	--

**Pearson Edexcel International Advanced Level**

**Friday 31 May 2024**

Morning (Time: 1 hour 45 minutes)

Paper  
reference

**WPH14/01**

**Physics**

**International Advanced Level**

**UNIT 4: Further Mechanics, Fields and Particles**

**You must have:**

Scientific calculator, ruler

Total Marks

### Instructions

- Use **black** ink or ball-point pen.
- If pencil is used for diagrams/sketches/graphs it must be dark (HB or B).
- **Fill in the boxes** at the top of this page with your name, centre number and candidate number.
- Answer **all** questions.
- Answer the questions in the spaces provided  
– *there may be more space than you need.*
- **Show all your working out** in calculations and **include units** where appropriate.

### Information

- The total mark for this paper is 90.
- The marks for **each** question are shown in brackets  
– *use this as a guide as to how much time to spend on each question.*
- In the question marked with an **asterisk (\*)**, marks will be awarded for your ability to structure your answer logically, showing how the points that you make are related or follow on from each other where appropriate.
- The list of data, formulae and relationships is printed at the end of this booklet.

### Advice

- Read each question carefully before you start to answer it.
- Try to answer every question.
- Check your answers if you have time at the end.

Turn over ►

P75810A

©2024 Pearson Education Ltd.  
F:1/1/1/



  
Pearson

## SECTION A

Answer ALL questions.

For questions 1–10, in Section A, select one answer from A to D and put a cross in the box .  
If you change your mind, put a line through the box  and then  
mark your new answer with a cross .

1 Which of the following is an SI base unit?

- A ampere
- B coulomb
- C joule
- D tesla

(Total for Question 1 = 1 mark)

2 A moving particle, P, decays. After the decay there are two particles, particle Q and particle R.

The diagram shows the momentum of particle Q and the momentum of particle R.

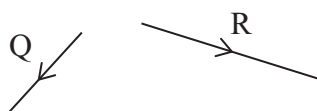

Which of the following is a correct vector diagram showing the momentum of particle P before the decay?

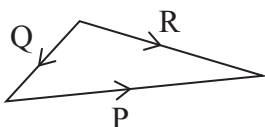

A

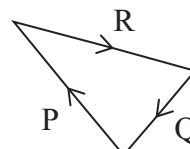

B

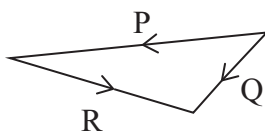

C

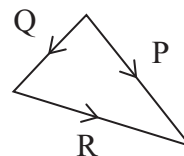

D

- A
- B
- C
- D

(Total for Question 2 = 1 mark)







Questions 3 and 4 refer to the information below.

A current-carrying wire is placed between two bar magnets, as shown.



The current in the wire is into the page.

3 Which diagram shows the direction of the force on the wire due to the magnetic field?

- A 
- B 
- C 
- D 

(Total for Question 3 = 1 mark)

4 When the magnetic flux density is  $0.024\text{T}$ , the force on the wire is  $4.8 \times 10^{-4}\text{N}$ .

The length of wire in the field is  $0.010\text{m}$ .

Which of the following gives the current, in amps, in the wire?

- A  $4.8 \times 10^{-4} \times 0.010 \times 0.024$
- B  $\frac{0.024}{0.010 \times 4.8 \times 10^{-4}}$
- C  $\frac{4.8 \times 10^{-4}}{0.010 \times 0.024}$
- D  $\frac{0.024 \times 0.010}{4.8 \times 10^{-4}}$

(Total for Question 4 = 1 mark)



5 Cyclotrons use electric fields and magnetic fields to give particles very high energy.

Which of the following statements is true for charged particles in cyclotrons?

- A The particles are accelerated by electric fields and magnetic fields.
- B The particles follow circular paths of constant radius.
- C The electric field changes direction when the particles are in the gap between the dees.
- D The magnetic field changes direction when the particles are in the gap between the dees.

(Total for Question 5 = 1 mark)

6 A capacitor of capacitance  $C$  is charged to a potential difference of  $V_0$ . The capacitor then discharges through a resistor of resistance  $R$ .

After time  $t$  the potential difference across the capacitor is  $V$ .

Which of the following gives the time constant for this circuit?

- A  $\frac{-t}{\ln(V - V_0)}$
- B  $\frac{-t}{\ln V + \ln V_0}$
- C  $\frac{-t}{\left(\frac{\ln V}{\ln V_0}\right)}$
- D  $\frac{-t}{\ln\left(\frac{V}{V_0}\right)}$

(Total for Question 6 = 1 mark)

7 In the early 1900s, scientists carried out alpha particle scattering experiments.

Which of the following statements is **not** a valid conclusion from their observations?

- A Most of the atom is empty space.
- B The nucleus is made of neutrons and protons.
- C There is a concentration of charge in the atom.
- D There is a concentration of mass in the atom.

(Total for Question 7 = 1 mark)



- 8 A ball collides with a wall and moves off in the opposite direction. The wall exerts a force on the ball during the collision.

The force-time graph for the collision is shown.

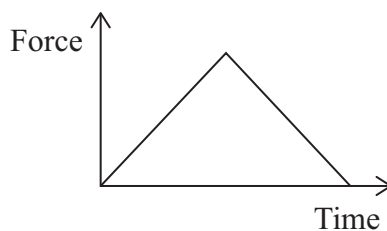

Which of the following is given by the area under the graph?

- A acceleration of the ball
- B average force acting on the ball
- C change in momentum of the ball
- D distance travelled by the ball

(Total for Question 8 = 1 mark)



**Questions 9 and 10 refer to the information below.**

A proton moving in a straight line with a speed  $v$  enters a magnetic field. The magnetic field is perpendicular to the direction of motion of the proton.

The proton follows a circular path of radius  $r$  in the magnetic field.

9 The path of the proton then decreases in radius.

Which of the following is a reason why the radius decreases?

- A The kinetic energy of the particle decreases.
- B The magnetic flux density decreases.
- C The mass of the proton increases.
- D The momentum of the proton increases.

(Total for Question 9 = 1 mark)

10 An alpha particle also moving in a straight line with the same speed  $v$  enters the same magnetic field.

The alpha particle follows a circular path in the magnetic field.

Which of the following is the initial radius of the path?

- A  $4r$
- B  $2r$
- C  $\frac{r}{2}$
- D  $\frac{r}{4}$

(Total for Question 10 = 1 mark)

**TOTAL FOR SECTION A = 10 MARKS**

DO NOT WRITE IN THIS AREA

DO NOT WRITE IN THIS AREA

DO NOT WRITE IN THIS AREA



SECTION B

Answer ALL questions in the spaces provided.

11 During an experiment in 1934, Chadwick fired alpha particles at beryllium atoms. Carbon atoms and neutral particles with the same mass as protons were produced. This led to the discovery of neutrons.

(a) Complete the equation for this process.

(2)



(b) A book about the Chadwick experiment includes the following statement:

“Chadwick’s experiment established that the neutron was a new fundamental particle and not an electron and proton joined together as suggested by Rutherford.”

Criticise this statement with reference to the structure of the neutron.

(2)

.....

.....

.....

.....

(Total for Question 11 = 4 marks)

DO NOT WRITE IN THIS AREA

DO NOT WRITE IN THIS AREA

DO NOT WRITE IN THIS AREA



P 7 5 8 1 0 A 0 7 3 2

12 A student investigated the charging of a capacitor. She measured the current in the capacitor circuit as the capacitor charged through a resistor.

- (a) Add to the diagram to show a suitable circuit for measuring the current as the capacitor charged.

(1)

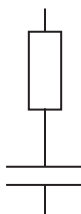

- (b) The graph shows how the current in the circuit varied with time as the capacitor charged.

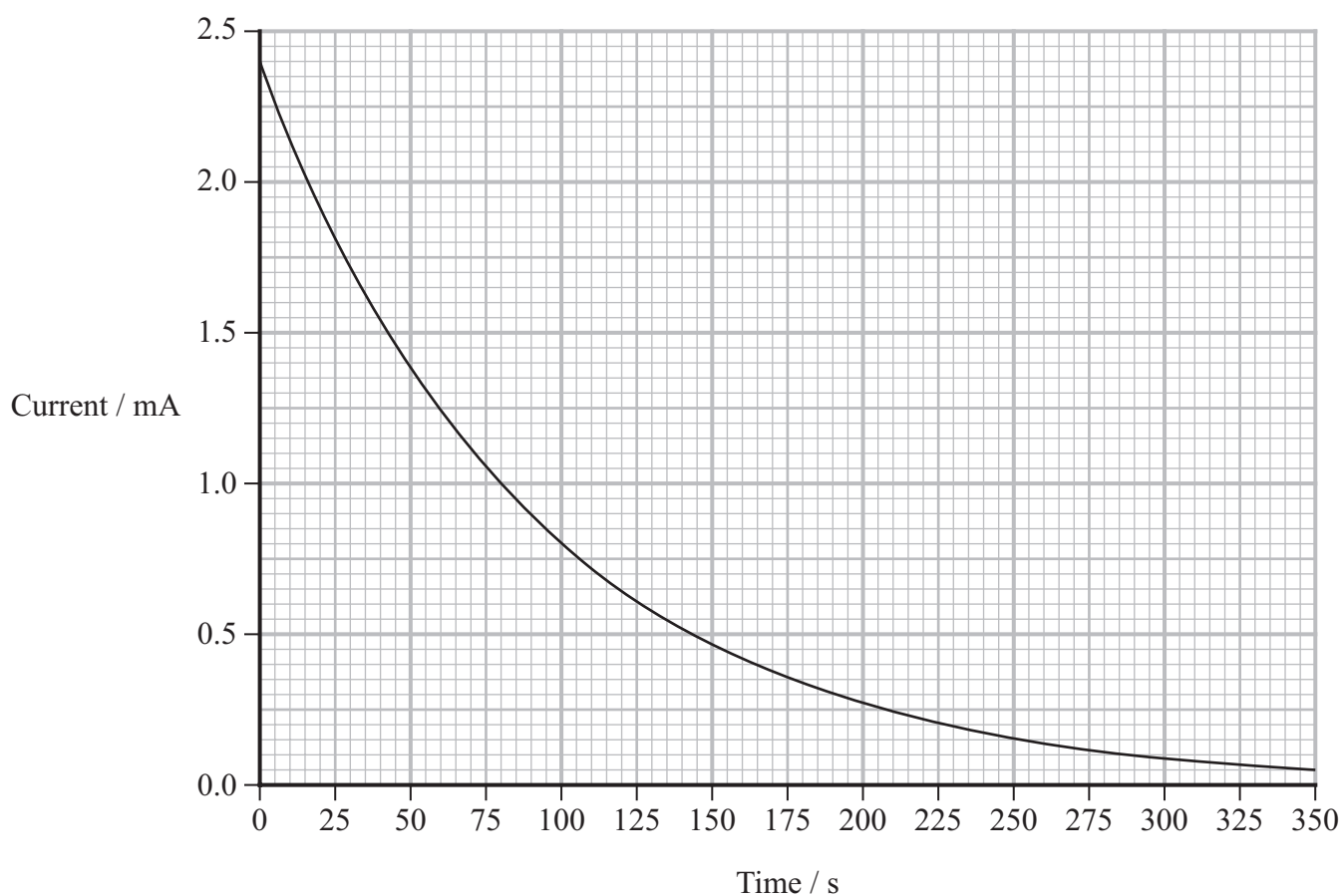



(i) The resistance of the resistor is  $5.1 \text{ k}\Omega$ .

Show that the capacitance of the capacitor is about  $0.02 \text{ F}$ .

(3)

(ii) Calculate the charge on the capacitor when it is fully charged.

(3)

Charge = .....

(iii) Calculate the energy stored by the capacitor when it is fully charged.

(2)

Energy = .....

**(Total for Question 12 = 9 marks)**

DO NOT WRITE IN THIS AREA

DO NOT WRITE IN THIS AREA

DO NOT WRITE IN THIS AREA



P 7 5 8 1 0 A 0 9 3 2

13 A student investigated the forces involved in circular motion, using a coin placed on a plastic disk.

The mass of the coin was 8.8 g. The diameter of the disk was 30 cm.

(a) The student determined the maximum frictional force between the coin and the disk by tilting the disk, as shown.

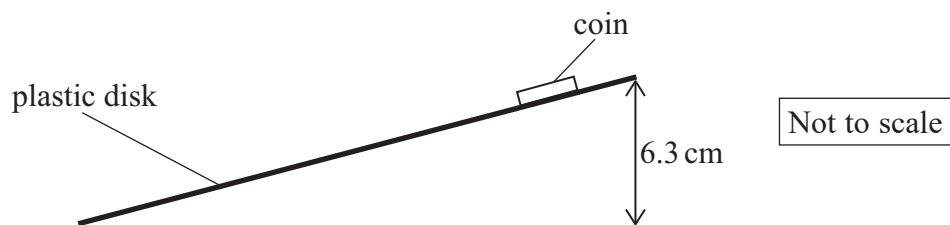

The edge was raised by 6.3 cm before the coin started to slide.

Show that the maximum frictional force was about 0.02 N.

(4)

.....

.....

.....

.....

.....

.....

.....

.....



- (b) The student placed the disk on a horizontal turntable and placed the coin on the disk, as shown below.

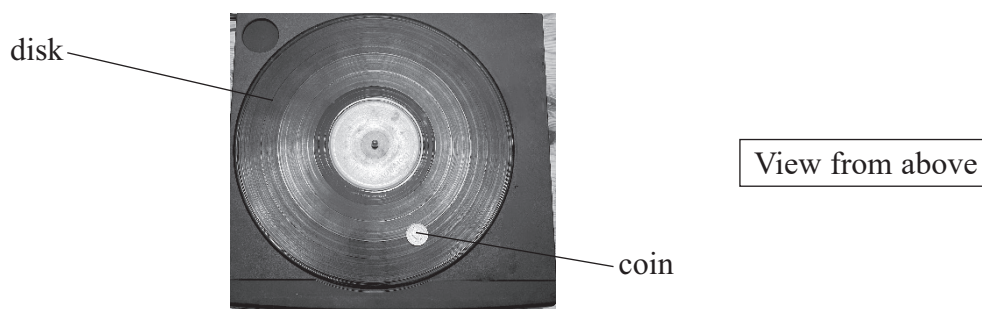

The disk rotated at 45 revolutions per minute.

- (i) Calculate the angular velocity of the disk.

(2)

Angular velocity = .....

- (ii) When the student placed the coin near the centre of the disk, the coin remained in position and rotated with the disk.

When the student placed the coin at the edge of the disk, the coin slid off the rotating disk.

The student estimated that the closest the coin could be to the edge of the disk without sliding off was about 5 cm.

Deduce whether this was a suitable estimate.

You should assume that the maximum frictional force is 0.02 N.

(3)

(Total for Question 13 = 9 marks)





(ii) Scientists search for new particles using high energy particle collisions.

The highest energy particle collisions involve colliding protons moving in opposite directions, each with energy 6800 GeV.

It is estimated that 11% of the total energy of a collision could be converted to the mass of a new particle.

Show that the maximum mass of a particle that can be produced is about  $3 \times 10^{-24}$  kg.

(3)

.....

.....

.....

.....

.....

.....

.....

(iii) Leptoquarks have not yet been observed.

Suggest why leptoquarks have not yet been observed.

(1)

.....

.....

(Total for Question 14 = 11 marks)

DO NOT WRITE IN THIS AREA

DO NOT WRITE IN THIS AREA

DO NOT WRITE IN THIS AREA



P 7 5 8 1 0 A 0 1 3 3 2

DO NOT WRITE IN THIS AREA

DO NOT WRITE IN THIS AREA

DO NOT WRITE IN THIS AREA

**BLANK PAGE**



DO NOT WRITE IN THIS AREA

DO NOT WRITE IN THIS AREA

DO NOT WRITE IN THIS AREA

- 15 An air table has a surface with many small holes. Air is blown through the holes. Plastic pucks can move freely over the table on a cushion of air.

The photograph shows the surface of an air table with two pucks on it.

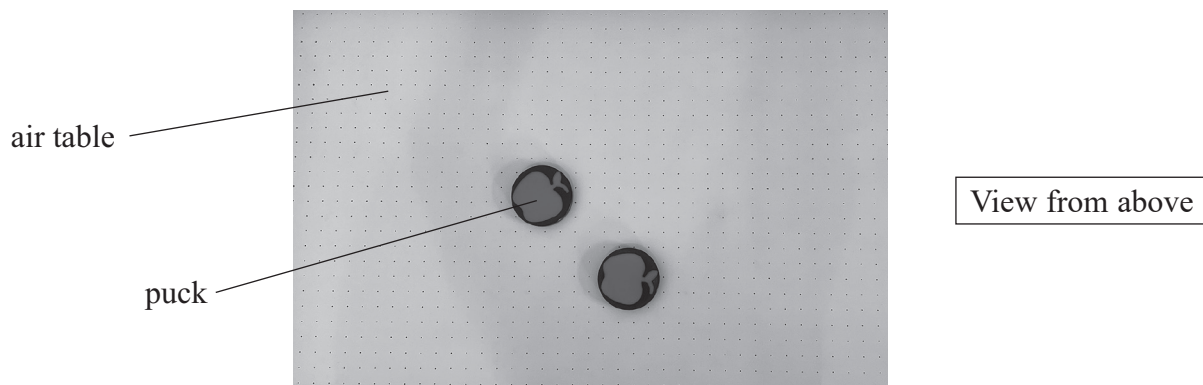

Some students used the air table to investigate conservation of momentum.

- (a) Explain how using the air table ensured that momentum was conserved in collisions between the pucks.

(2)

.....

.....

.....

.....

- (b) The students observed several collisions between two identical pucks, A and B. One puck was stationary before each collision.

They noticed that after each collision the two pucks seemed to follow paths at  $90^\circ$  to each other.

The diagram shows one of the collisions.

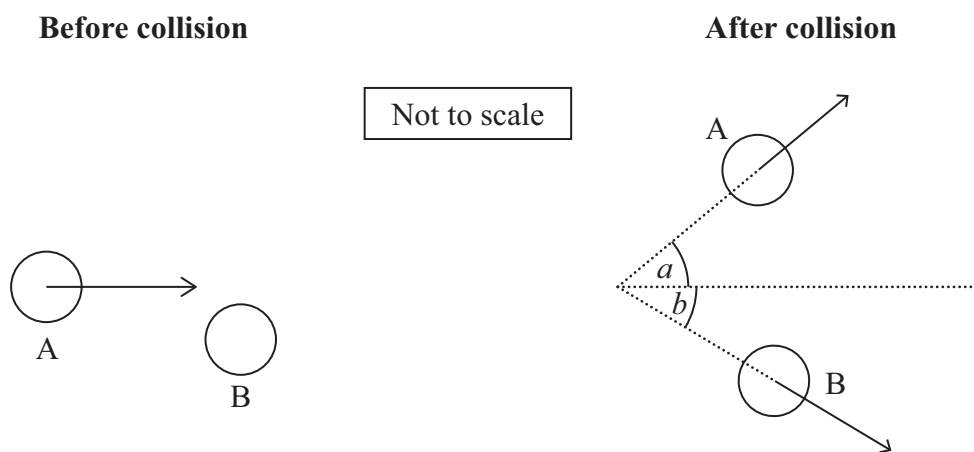

The students recorded the following data for this collision.

initial momentum of A	$0.046 \text{ kg m s}^{-1}$
angle $a$	$33^\circ$
final momentum of A	$0.039 \text{ kg m s}^{-1}$





- (i) Deduce whether the angle between the paths of the pucks after the collision was  $90^\circ$ .

You should use the principle of conservation of momentum.

(5)

- (ii) Deduce whether the collision was elastic.

mass of each puck =  $0.110\text{kg}$

(5)

(Total for Question 15 = 12 marks)

DO NOT WRITE IN THIS AREA

DO NOT WRITE IN THIS AREA

DO NOT WRITE IN THIS AREA



P 7 5 8 1 0 A 0 1 7 3 2

16 Scientists at CERN are planning an upgrade to the Large Hadron Collider called the Large Hadron Electron Collider (LHeC).

The scientists plan to use a linear accelerator (linac) to produce high energy electrons. Collisions between these electrons and high energy protons will allow the structure of protons to be investigated.

(a) The high energy electrons produced will have energy 60 GeV.

Show that these electrons will be travelling at relativistic speeds.

(3)

.....

.....

.....

.....

.....

.....



DO NOT WRITE IN THIS AREA

DO NOT WRITE IN THIS AREA

DO NOT WRITE IN THIS AREA

\*(b) The diagram shows the start section of a linac and the end section of a linac.

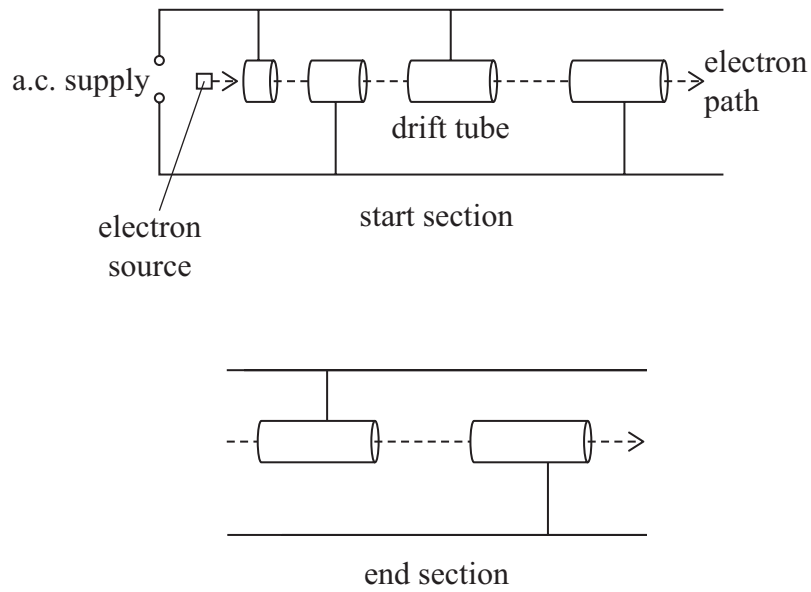

Explain how a linac produces high energy electrons.

You should refer to the a.c. supply and to the length of the drift tubes in each section.

(6)

.....

.....

.....

.....

.....

.....

.....

.....

.....

.....

.....

.....

.....

.....

.....

.....

.....

.....

.....

.....

.....

.....

.....

(c) Explain why high energies are required to investigate the structure of protons.

(3)

.....

.....

.....

.....

.....

.....

.....

**(Total for Question 16 = 12 marks)**

DO NOT WRITE IN THIS AREA

DO NOT WRITE IN THIS AREA

DO NOT WRITE IN THIS AREA



17 Scientists are developing safe methods for removing old satellites from orbit.

Some scientists plan to use electrostatic forces. A spacecraft will fire a beam of electrons at a satellite. This will give the satellite a negative charge and the spacecraft a positive charge.

There will be an electrostatic force of attraction between the satellite and the spacecraft. The spacecraft will then move away, taking the satellite with it.

- (a) The diagram shows the electric field around the spacecraft X and the satellite Y when they have equal and opposite charge. You may assume that the spacecraft and the satellite are both spherical and have the same diameter.

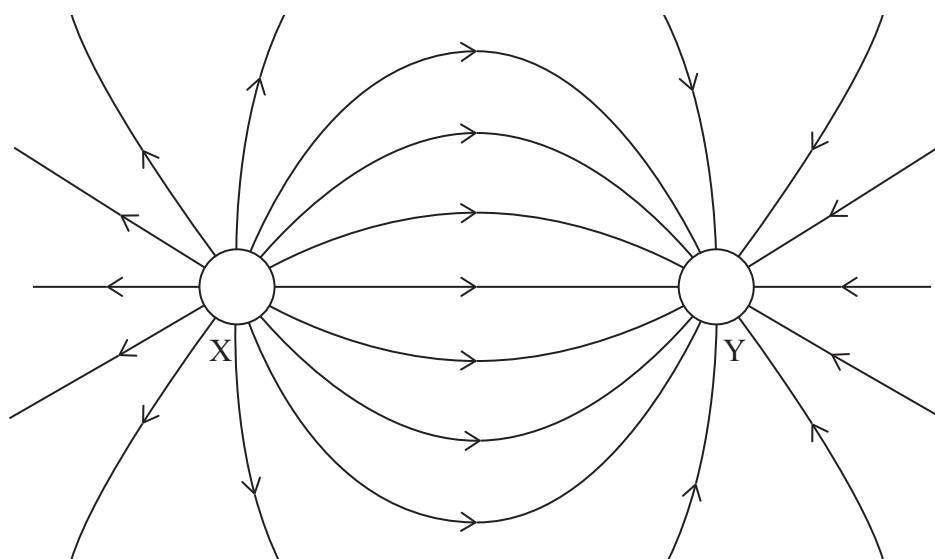

- (i) Add dashed lines to the electric field diagram to show equipotentials at intervals of equal potential difference.

(3)

- (ii) Label the equipotential that represents 0V.

(1)



(b) After some time, the charge on the spacecraft will be  $+1.5 \times 10^{-6} \text{ C}$  and the charge on the satellite will be  $-1.5 \times 10^{-6} \text{ C}$ .

(i) Calculate the minimum energy, in joules, required for an electron leaving the surface of the spacecraft to reach the surface of the satellite.

Assume that the charge on each object does **not** affect the potential at the surface of the other object.

radius of satellite = 2.5 m  
radius of spacecraft = 2.5 m

(3)

.....  
.....  
.....  
.....  
.....

Minimum energy = ..... J



- (ii) The spacecraft moves to a new position, taking the satellite with it.

The distance between the satellite and the spacecraft remains constant, so the electrostatic force is constant.

The scientists estimate that the satellite could be moved a distance of 300 km in about 60 days.

Deduce whether this estimate is correct.

Assume gravitational forces are negligible and the satellite is initially at rest.

distance between centre of satellite and centre of spacecraft = 20 m

mass of satellite = 2500 kg

(4)

- (c) In reality, the magnitude of the positive charge on the spacecraft may be greater than the magnitude of the negative charge on the satellite.

Suggest why.

(1)

(Total for Question 17 = 12 marks)



18 In some car engines the power is provided by burning a mixture of fuel and air.

The photograph shows a spark plug. The spark plug creates a spark that ignites the mixture. A very high potential difference (p.d.) across the gap in the spark plug is needed to produce the spark.

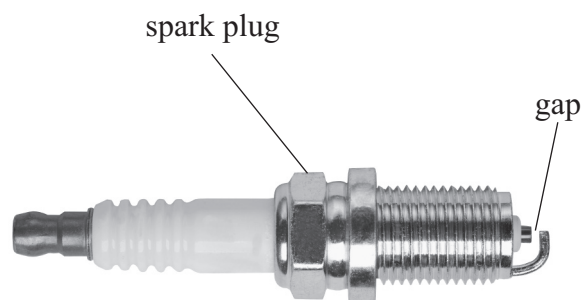

(Source: © Miro Novak / Alamy Stock Photo)

The very high p.d. is produced using the arrangement shown in the diagram below.

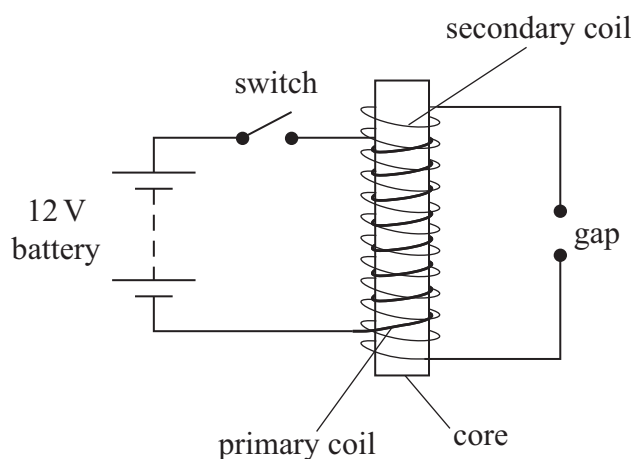

The switch is closed and the current in the primary coil increases to a maximum value. The switch is then opened and the current falls to zero almost immediately. The secondary coil produces a large p.d., creating an electric field strong enough to cause a spark across the gap.

(a) Explain how a p.d. is produced across the secondary coil when the switch is opened.

(3)





DO NOT WRITE IN THIS AREA

DO NOT WRITE IN THIS AREA

DO NOT WRITE IN THIS AREA

(b) The distance across the gap in the spark plug is 0.75 mm.  
Calculate the electric field strength in the gap when the switch is opened.  
Assume the electric field in the gap is uniform.

- maximum magnetic flux density = 0.34 T
- number of turns on secondary coil = 30 000
- diameter of secondary coil = 16 mm
- time for primary current to fall to zero =  $2.0 \times 10^{-5}$  s

(5)

.....

.....

.....

.....

.....

.....

.....

.....

.....

.....

.....

Electric field strength = .....



(c) When the switch in the circuit is closed, the current increases to a maximum value, as shown.

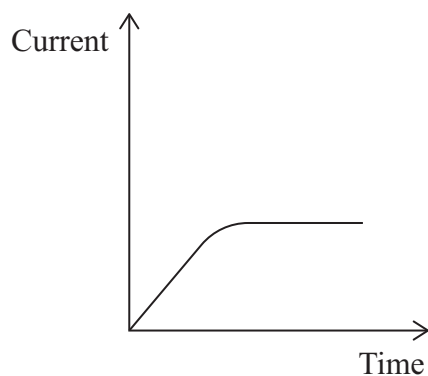

Explain why the current does not increase to its maximum value instantaneously.

You should refer to Lenz's law.

(3)

.....

.....

.....

.....

.....

.....

.....

(Total for Question 18 = 11 marks)

**TOTAL FOR SECTION B = 80 MARKS**  
**TOTAL FOR PAPER = 90 MARKS**



### List of data, formulae and relationships

Acceleration of free fall	$g = 9.81 \text{ m s}^{-2}$	(close to Earth's surface)
Boltzmann constant	$k = 1.38 \times 10^{-23} \text{ J K}^{-1}$	
Coulomb's law constant	$k = 1/4\pi\epsilon_0$ $= 8.99 \times 10^9 \text{ N m}^2 \text{ C}^{-2}$	
Electron charge	$e = -1.60 \times 10^{-19} \text{ C}$	
Electron mass	$m_e = 9.11 \times 10^{-31} \text{ kg}$	
Electronvolt	$1 \text{ eV} = 1.60 \times 10^{-19} \text{ J}$	
Gravitational constant	$G = 6.67 \times 10^{-11} \text{ N m}^2 \text{ kg}^{-2}$	
Gravitational field strength	$g = 9.81 \text{ N kg}^{-1}$	(close to Earth's surface)
Permittivity of free space	$\epsilon_0 = 8.85 \times 10^{-12} \text{ F m}^{-1}$	
Planck constant	$h = 6.63 \times 10^{-34} \text{ J s}$	
Proton mass	$m_p = 1.67 \times 10^{-27} \text{ kg}$	
Speed of light in a vacuum	$c = 3.00 \times 10^8 \text{ m s}^{-1}$	
Stefan-Boltzmann constant	$\sigma = 5.67 \times 10^{-8} \text{ W m}^{-2} \text{ K}^{-4}$	
Unified atomic mass unit	$u = 1.66 \times 10^{-27} \text{ kg}$	

#### Unit 1

##### Mechanics

Kinematic equations of motion	$s = \frac{(u + v)t}{2}$
	$v = u + at$
	$s = ut + \frac{1}{2}at^2$
	$v^2 = u^2 + 2as$

Forces	$\Sigma F = ma$
	$g = \frac{F}{m}$
	$W = mg$

Momentum	$p = mv$
----------	----------

Moment of force	moment = $Fx$
-----------------	---------------

Work and energy	$\Delta W = F\Delta s$
	$E_k = \frac{1}{2}mv^2$

	$\Delta E_{\text{grav}} = mg\Delta h$
--	---------------------------------------

Power	$P = \frac{E}{t}$
	$P = \frac{W}{t}$



Efficiency

$$\text{efficiency} = \frac{\text{useful energy output}}{\text{total energy input}}$$

$$\text{efficiency} = \frac{\text{useful power output}}{\text{total power input}}$$

*Materials*

Density

$$\rho = \frac{m}{V}$$

Stokes' law

$$F = 6\pi\eta rv$$

Hooke's law

$$\Delta F = k\Delta x$$

Elastic strain energy

$$\Delta E_{\text{el}} = \frac{1}{2}F\Delta x$$

Young modulus

$$E = \frac{\sigma}{\varepsilon} \text{ where}$$

$$\text{Stress } \sigma = \frac{F}{A}$$

$$\text{Strain } \varepsilon = \frac{\Delta x}{x}$$

DO NOT WRITE IN THIS AREA

DO NOT WRITE IN THIS AREA

DO NOT WRITE IN THIS AREA



**Unit 2***Waves*

Wave speed	$v = f\lambda$
Speed of a transverse wave on a string	$v = \sqrt{\frac{T}{\mu}}$
Intensity of radiation	$I = \frac{P}{A}$
Refractive index	$n_1 \sin \theta_1 = n_2 \sin \theta_2$ $n = \frac{c}{v}$
Critical angle	$\sin C = \frac{1}{n}$
Diffraction grating	$n\lambda = d \sin \theta$

*Electricity*

Potential difference	$V = \frac{W}{Q}$
Resistance	$R = \frac{V}{I}$
Electrical power, energy	$P = VI$ $P = I^2R$ $P = \frac{V^2}{R}$ $W = VI t$
Resistivity	$R = \frac{\rho l}{A}$
Current	$I = \frac{\Delta Q}{\Delta t}$ $I = nqvA$
Resistors in series	$R = R_1 + R_2 + R_3$
Resistors in parallel	$\frac{1}{R} = \frac{1}{R_1} + \frac{1}{R_2} + \frac{1}{R_3}$

*Particle nature of light*

Photon model	$E = hf$
Einstein's photoelectric equation	$hf = \phi + \frac{1}{2}mv_{\max}^2$
de Broglie wavelength	$\lambda = \frac{h}{p}$



**Unit 4***Further mechanics*

Impulse

$$F\Delta t = \Delta p$$

Kinetic energy of a non-relativistic particle

$$E_k = \frac{p^2}{2m}$$

Motion in a circle

$$v = \omega r$$

$$T = \frac{2\pi}{\omega}$$

$$a = \frac{v^2}{r}$$

$$a = r\omega^2$$

Centripetal force

$$F = ma = \frac{mv^2}{r}$$

$$F = mr\omega^2$$

*Electric and magnetic fields*

Electric field

$$E = \frac{F}{Q}$$

Coulomb's law

$$F = \frac{Q_1 Q_2}{4\pi\epsilon_0 r^2}$$

$$E = \frac{Q}{4\pi\epsilon_0 r^2}$$

$$E = \frac{V}{d}$$

Electrical potential

$$V = \frac{Q}{4\pi\epsilon_0 r}$$

Capacitance

$$C = \frac{Q}{V}$$

Energy stored in capacitor

$$W = \frac{1}{2} QV$$

$$W = \frac{1}{2} CV^2$$

$$W = \frac{1}{2} \frac{Q^2}{C}$$

Capacitor discharge

$$Q = Q_0 e^{-t/RC}$$



Resistor-capacitor discharge

$$I = I_0 e^{-t/RC}$$

$$V = V_0 e^{-t/RC}$$

$$\ln Q = \ln Q_0 - \frac{t}{RC}$$

$$\ln I = \ln I_0 - \frac{t}{RC}$$

$$\ln V = \ln V_0 - \frac{t}{RC}$$

In a magnetic field

$$F = Bqv \sin \theta$$

$$F = BIl \sin \theta$$

Faraday's and Lenz's laws

$$\mathcal{E} = \frac{-d(N\phi)}{dt}$$

*Nuclear and particle physics*

In a magnetic field

$$r = \frac{p}{BQ}$$

Mass-energy

$$\Delta E = c^2 \Delta m$$

DO NOT WRITE IN THIS AREA

DO NOT WRITE IN THIS AREA

DO NOT WRITE IN THIS AREA



DO NOT WRITE IN THIS AREA

DO NOT WRITE IN THIS AREA

DO NOT WRITE IN THIS AREA

**BLANK PAGE**

